

OWNER'S MANUAL —  
Please read before using this equipment.

**49-2516**

Thanks for purchasing a RadioShack 1/3-Inch Color Indoor/Outdoor Camera. Your camera is super-small and compact. It is designed for use with a RadioShack 10-Inch Single Channel Security Monitor (Cat. No. 49-2514) to provide a safe and secure environment.

**Built-in Speaker and Microphone** — allow 2-way communication with compatible equipment.

**Color-B&W Auto Switching** — enables better night vision by automatically turning to B&W when illumination falls below 2 Lux.

**CMOS (Complementary Metal-Oxide Semiconductor) Sensor** — provides superior-resolution color and B&W images.

**Passive Infrared (PIR) Sensor** — detects motion up to 16.5 feet away from an angle of up to 100°.

**Weatherproof** — so you can mount the camera indoors or outdoors.

## CAMERA MOUNTING GUIDELINES

Carefully plan where and how you will position the camera and where you will route the cable that connects the camera to the monitor. When planning the installation:

### NOTE

Though the camera is highly sensitive, it cannot "see" over a wide area in total darkness. To assist the camera's night vision, install a 100-watt incandescent lamp (rich in infrared radiation) to illuminate the camera's viewing area. You can also use a small incandescent flood lamp. Halogen lamps, other high pressure outdoor lamps, and fluorescent lighting are infrared-poor and not recommended.

- Select a location for the camera that provides a clear view of the area you want to monitor, is free from dust, and is not in direct sunlight or in line-of-sight of a strong light source.
- Do not install the camera in a location where it will be exposed to high humidity or rain.
- Plan the cable's route so it is not close to power or telephone lines, transformers, microwave ovens, or other electrical equipment that could interfere with (or accept interference from) the system.
- Select a location for the camera that has an ambient temperature between -4°F (-20°C) and 122°F (50°C).
- If you plan to install the camera in a location that has conditions not recommended in this manual, consult with a professional installer and consider use of a separate camera cover or housing.

## MOUNTING AND INSTALLING THE CAMERA

You can mount the camera indoors or outdoors in a permanent location such as a wall or on a movable platform (such as a tripod) for mounting on a desk, shelf, or table.

1. Use the base of the camera as a guide, mark the locations for the screw holes on the mounting surface.
2. Drill a starter hole at each marked location. If necessary, drill a third hole (at least 14 mm in diameter) below the mounting holes to permit the camera's cable to be inserted through the mounting surface.

3. If necessary, insert the supplied drywall anchors into the screw holes.
4. Insert one of the two supplied screws through each of the screw holes in the bracket and into the mounting surface, then tighten each screw until the base is secure.
5. Loosen the screw from the camera's arm-sleeve and fully insert the base's arm into the sleeve. Then secure the

arm and sleeve together by tightening the screw.

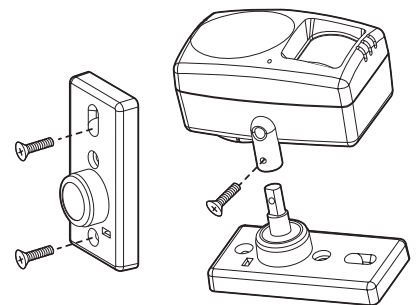

## SETTING UP THE CAMERA

### CONNECTING DIRECTLY TO THE MONITOR

1. Connect the camera's mini-DIN plug into the supplied 59-foot cable's mini-DIN

socket.

2. Connect the 59-foot cable to the monitor's mini-DIN port.

### ! IMPORTANT !

If an icon appears at the end of a paragraph, go to the box on that page with the corresponding icon for pertinent information.

— Warning    — Important    — Note    — Caution    — Hint

## USING A/V INPUTS OR A SWITCHBOX

1. Connect the extension cable's mini-DIN plug into the supplied 6-inch adapter cable's mini-DIN socket.

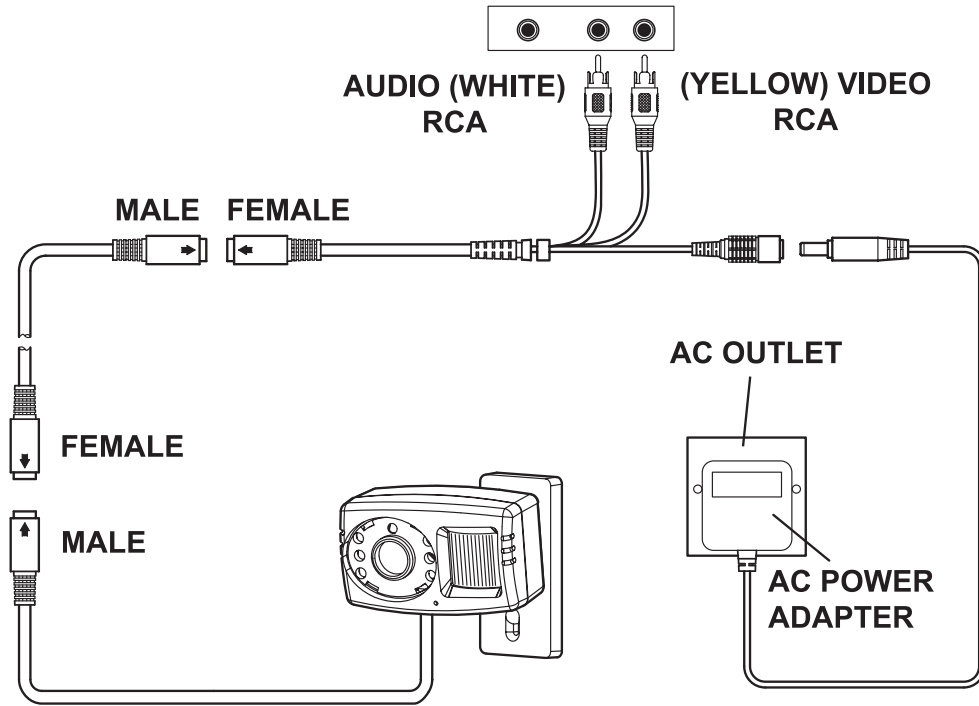

2. Connect the adapter cable's yellow end to your TV's video jack, and connect the white end to your TV's audio jack.
3. Connect the adapter cable's red power socket to the supplied DC adapter's barrel plug.
4. Connect the DC adapter to a standard AC outlet.

## CARE

Keep the camera dry; if it gets wet, wipe it dry immediately. Use and store the camera only in normal temperature environments. Handle

the camera carefully; do not drop it. Keep the camera away from dust and dirt, and wipe it

with a damp cloth occasionally to keep it looking new.

## SERVICE AND REPAIR

If your camera is not performing as it should, take it to your local RadioShack store for assistance. Modifying or tampering with the



camera's internal components can cause a malfunction and might invalidate its warranty.

## SPECIFICATIONS

Input Voltage .....	15 V DC
Lens Angle .....	90° (viewing angle is 76°)
Video Output .....	1.0 Vp-p, 75 Ohm
Audio Output .....	1.2 Vp-p
Maximum Audio Output Power (Speaker) .....	0.4 W
Audio Distortion .....	<1%
Audio Frequency Response .....	300 Hz to 5 KHz
Resolution .....	250,000 pixel, 330 TV lines
Minimum Illumination .....	2 lux @ F2.0 (without IR LED) 0 lux @ F2.0 (with IR LED)
Operating Temperature .....	4° to 122°F (-20° to 50°C)
PIR Maximum Range .....	100° × 16.5ft

PIR Detection Angle (H/V) ..	Horizontal 100° Vertical 45°
Dimensions .....	2 <sup>1</sup> / <sub>16</sub> × 3 <sup>5</sup> / <sub>16</sub> × 1 <sup>3</sup> / <sub>4</sub> inches (52 × 84 × 45 mm)
Weight (with wire) .....	5.8 oz (165 g)

Specifications are typical; individual units might vary. Specifications are subject to change and improvement without notice.

<b>WARNING:</b> To reduce the risk of fire or shock hazard, do not expose this product to rain or moisture.	
	<b>CAUTION</b>
<b>RISK OF ELECTRIC SHOCK DO NOT OPEN</b>	
<b>CAUTION:</b> TO REDUCE THE RISK OF ELECTRICAL SHOCK, DO NOT REMOVE COVER OR BACK. NO USER-SERVICEABLE PARTS INSIDE. REFER SERVICING TO QUALIFIED PERSONNEL.	
	The lightning symbol is intended to alert you to the presence of uninsulated dangerous voltage within this product's enclosure that might be of sufficient magnitude to constitute a risk of electric shock. Do not open the product's case.
	The exclamation mark symbol is intended to inform you that important operating and maintenance instructions are included in the literature accompanying this product.